

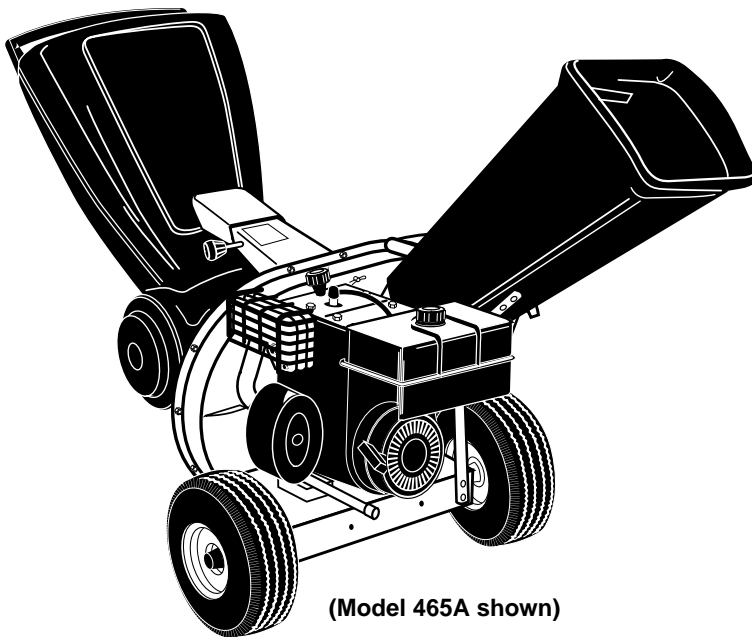

OPERATOR'S MANUAL

**Chipper - Shredders
Model Series
462 thru 465**



(Model 465A shown)



IMPORTANT: READ SAFETY RULES AND INSTRUCTIONS CAREFULLY

Warning: This unit is equipped with an internal combustion engine and should not be used on or near any unimproved forest-covered, brush-covered or grass-covered land unless the engine's exhaust system is equipped with a spark arrester meeting applicable local or state laws (if any). If a spark arrester is used, it should be maintained in effective working order by the operator. In the State of California the above is required by law (Section 4442 of the California Public Resources Code). Other states may have similar laws. Federal laws apply on federal lands. A spark arrester for the muffler is available through your nearest engine authorized service dealer or contact the service department, P.O. Box 368022 Cleveland, Ohio 44136-9722.

MTD PRODUCTS INC. P.O. BOX 368022 CLEVELAND, OHIO 44136-9722

SECTION 1: IMPORTANT SAFE OPERATION PRACTICES



WARNING: THIS SYMBOL POINTS OUT IMPORTANT SAFETY INSTRUCTIONS WHICH, IF NOT FOLLOWED, COULD ENDANGER THE PERSONAL SAFETY AND/OR PROPERTY OF YOURSELF AND OTHERS. READ AND FOLLOW ALL INSTRUCTIONS IN THIS MANUAL BEFORE ATTEMPTING TO OPERATE YOUR CHIPPER-SHREDDER. FAILURE TO COMPLY WITH THESE INSTRUCTIONS MAY RESULT IN PERSONAL INJURY. WHEN YOU SEE THIS SYMBOL: HEED ITS WARNING.



WARNING: The Engine Exhaust from this product contains chemicals known to the State of California to cause cancer, birth defects or other reproductive harm.



DANGER: Your chipper-shredder was built to be operated according to the rules for safe operation in this manual. As with any type of power equipment, carelessness or error on the part of the operator can result in serious injury. This chipper-shredder is capable of amputating fingers and hands and throwing objects. Failure to observe the following safety instructions could result in serious injury or death.

1. GENERAL OPERATION

- Read this operator's manual carefully in its entirety before attempting to assemble this machine. Read, understand, and follow all instructions on the machine and in the manual(s) before operation. Be completely familiar with the controls and the proper use of the machine before operating it. Keep this manual in a safe place for future and regular reference and for ordering replacement parts.
- Your chipper-shredder is a powerful tool, not a plaything. Therefore, exercise extreme caution at all times. Your unit has been designed to perform two jobs; to chip and shred vegetation found in a normal yard. Do not use it for any other purpose.
- Never allow children under age 16 to operate the unit. Children 16 years and older should only operate the unit under close parental supervision. Only responsible individuals who are familiar with these rules of safe operation should be allowed to use your unit.
- Keep the area of operation clear of all persons, particularly small children and pets. Stop the engine when they are in the vicinity of the unit. Keep work area clean and clear of branches or obstacles which could cause you to stumble or fall.
- When feeding material into this equipment, be extremely careful that pieces of metal, rocks, bottles, cans or other foreign objects are not included. Personal injury or damage to the machine could result.
- Wear sturdy, rough-soled work shoes and close fitting slacks and shirt. Shirt and slacks that cover the arms and legs and steel-toed shoes are recommended. Do not wear loose fitting clothes or jewelry and secure hair so it is above shoulder length. They can be caught in moving parts. Never operate a unit in bare feet, sandals or sneakers. Wear gloves when feeding material in the chipper chute or shredder hopper.
- Always wear safety glasses or safety goggles, during operation and while performing an adjustment or repair, to protect eyes from foreign objects that may be thrown from the machine.
- Never place your hands, feet, or any part of your body into the shredder hopper, chipper chute, discharge opening, or near any moving part while the engine is running. Keep clear of the discharge opening at all times. If it becomes necessary to push material into the chipper chute or shredder hopper, use a small diameter stick, NOT YOUR HANDS.
- If it is necessary for any reason to unclog the feed intake or discharge openings or to inspect or repair any part of the machine where a moving part can come in contact with your body or clothing, stop the machine, allow it to cool, disconnect the spark plug wire from the spark plug and move it away from the spark plug before attempting to unclog, inspect or repair.
- Do not operate unit while under the influence of alcohol or drugs.
- The machine should only be operated on a level surface. Never operate your unit on a slippery, wet, muddy or icy surface. Keep your work area clean and clear of branches or obstacles which could cause you to stumble and fall. Do not overreach. Maintaining proper footing and balance is essential to preventing accidents.
- Do not allow an accumulation of processed material to build up in the discharge area as this will prevent proper discharge and can result in kickback from the chipper chute.
- Keep your face and body back from chipper chute to avoid accidental bounce back of any material.
- Do not transport machine while engine is running.

- If the cutting mechanism strikes a foreign object or if your machine should start making an unusual noise or vibration, immediately stop the engine and allow the machine to come to a complete stop. Disconnect the spark plug wire and move it away from the spark plug. Take the following steps.
 - Inspect for damage.
 - Repair or replace any damaged parts.
 - Check for any loose parts and tighten to assure continued safe operation.
- Never attempt to attach or remove catcher bag when engine is running. Shut the engine off and wait for the impeller to come to a complete stop. The impeller continues to rotate for a few seconds after the engine is shut off. Never place any part of the body in the impeller area until you are sure the impeller has stopped rotating.
- Muffler and engine become hot and can cause a burn. Do not touch.
- Do not allow leaves or other debris to build up on engine's muffler. The debris could ignite and cause a fire.
- Do not attempt to shred or chip material larger than specified in this manual. Personal injury or damage to the machine could result.
- Do not operate engine if air cleaner or cover over carburetor air intake is removed, except for adjustment. Removal of such parts could create a fire hazard.
- Only use accessories approved for this machine by the manufacturer. Read, understand, and follow all instructions provided with the approved accessory.
- If situations occur which are not covered by this manual, use care and good judgment. Contact your dealer for assistance.
- Keep discharge chute deflector, chipper chute door, and all other guards and safety devices in place and operating properly.
- Only operate unit in good daylight. Do not operate unit at night or in dark areas where your vision may be impaired.

2. CHILDREN

Tragic accidents can occur if the operator is not alert to the presence of small children. Children are often attracted to the chipper-shredder and the chipping and shredding activity. Never assume that children will remain where you last saw them.

- Keep children out of the work area and under the watchful eye of a responsible adult other than the operator.
- Be alert and turn the unit off if a child enters the area.
- Never allow children under the age of 16 to operate the chipper-shredder.



WARNING - YOUR RESPONSIBILITY: Restrict the use of this power machine to persons who read, understand and follow the warnings and instructions in this manual and on the machine.

3. SERVICE

- Use extreme care in handling gasoline and other fuels. They are extremely flammable and the vapors are explosive.
- Store fuel and oil in approved containers, away from heat and open flame, and out of the reach of children. Check and add fuel before starting the engine. Never remove gas cap or add fuel while the engine is running. Allow engine to cool at least two minutes before refueling.
- Replace gasoline cap securely and wipe off any spilled gasoline before starting the engine as it may cause a fire or explosion.
- Extinguish all cigarettes, cigars, pipes and other sources of ignition.
- Never refuel unit indoors because flammable vapors will accumulate in the area.
- Never store the machine or fuel container inside where there is an open flame or spark such as a gas hot water heater, space heater, clothes dryer or furnace.
- Never run your machine in an enclosed area as the exhaust from the engine contains carbon monoxide, which is an odorless, tasteless and deadly poisonous gas.
- To reduce fire hazard, keep engine and muffler free of leaves, grass, and other debris build-up. Clean up fuel and oil spillage. Allow unit to cool at least 5 minutes before storing.
- Before cleaning, repairing, or inspecting, make certain the impeller and all moving parts have stopped. Disconnect the spark plug wire and keep wire away from spark plug to prevent accidental starting. Do not use flammable solutions to clean air filter.
- Check the blade and engine mounting screws at frequent intervals for proper tightness. Also visually inspect blades for wear and/or damage (e.g., bent, cracked). Replace with blades which meet original equipment specifications.
- Keep all nuts, bolts, and screws tight to be sure the equipment is in safe working condition.
- Never tamper with safety devices. Check their proper operation regularly.
- After striking a foreign object, immediately stop the engine, disconnect the spark plug wire from the spark plug, and thoroughly inspect the unit for any damage. Repair damage before starting and operating unit.
- Do not alter or tamper with the engine's governor setting. The governor controls the maximum safe operating speed of the engine. Overspeeding the engine is dangerous and will cause damage to the engine and to other moving parts of the machine.

SECTION 2: SAFETY LABELS FOUND ON YOUR UNIT:

⚠ DANGER

TO AVOID SERIOUS INJURY:

- DO NOT DEPOSIT BRANCHES LARGER THAN 1/2 INCH DIAMETER INTO THIS HOPPER.
- WEAR APPROVED SAFETY GLASSES, GLOVES AND EAR PROTECTION. AVOID LOOSE FITTING CLOTHING.
- Read the Owner's Manual before starting and using this chipper/shredder.
- Keep hands, feet, face and clothing out of shredder hopper inlet and chipper chute inlet.
- Keep hands, feet, face and clothing away from discharge area and moving parts.
 - Keep hands and feet out of discharge opening when chipper/shredder is running. The rotating cutting blades inside opening will cause serious personal injury.
 - Do not transport unit with engine running.
 - Keep bystanders, children, and pets away from operating and discharge

- If chipper/shredder jams or becomes clogged, shut engine off right away and wait for all moving parts to come to a complete stop. Disconnect the spark plug wire and prevent it from touching the spark plug. Use only a long wooden stick (or long-handled shovel) to clear away discharged materials or blockages.
- Keep all shields and guards in place and securely attached.
- DO NOT use hands or feet to clear material from the discharge area or discharge opening.
- DO NOT install parts, or remove, adjust, or service the discharge screen or any other part while the chipper/shredder is running. DO NOT operate the chipper/shredder on uneven ground, or on a paved, gravel, or hard surface. DO NOT run engine in an enclosed area-exhaust gas contains poisonous carbon monoxide fumes.

⚠ WARNING

TO AVOID A FIRE HAZARD, KEEP LEAVES, GRASS, AND OTHER COMBUSTIBLE MATERIALS AWAY FROM HOT ENGINE AND MUFFLER.

AC
0158A

⚠ DANGER

ASSEMBLE CHUTE DEFLECTOR TO THIS UNIT BEFORE OPERATING MACHINE.

SAFETY GLASSES SHOULD BE WORN

DON'T DEPOSIT MATERIAL LARGER THAN 1/2 INCH DIAMETER IN THE HOPPER THIS MAY CAUSE DAMAGE TO SHREDDING MACHINE.

9326A

WARNING: DO NOT OPERATE THIS MACHINE UNLESS THE CHUTE DEFLECTOR HAS BEEN PROPERLY INSTALLED AND IS SECURED WITH THE HAND KNOBS.

⚠ DANGER

ROTATING CUTTING BLADES. KEEP HANDS AND FEET OUT OF OPENING WHILE MACHINE IS RUNNING.

9342 A

⚠ DANGER

ROTATING CUTTING BLADES. KEEP HANDS AND FEET OUT OF OPENINGS WHILE MACHINE IS RUNNING.

3047

SECTION 3: FINDING YOUR MODEL NUMBER

This Operator's Manual is an important part of your new chipper-shredder. It will help you assemble, prepare and maintain your chipper-shredder. Please read and understand what it says.

Before you prepare your chipper-shredder for its first use, please locate the model plate and copy the information from it in this Operator's Manual. The information on the model plate is very important if you need help from your dealer or the MTD Customer Support Department.

- Every chipper shredder has a model plate. You can locate it by standing behind the unit in the operating position and looking down at the frame next to the engine.
- The model plate will look like this.

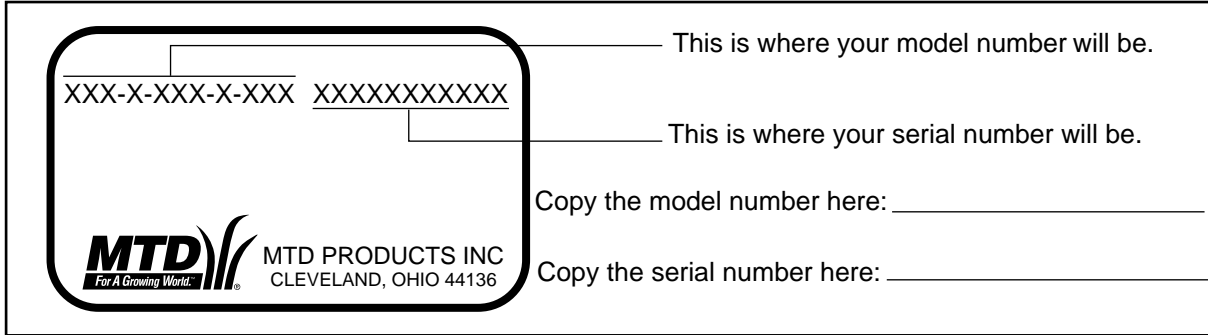

SECTION 4: CALLING CUSTOMER SUPPORT

If you are having difficulty assembling this product or if you have any question regarding the controls, operation or maintenance of this chipper shredder, please call the Customer Support Department. You can reach them by calling:

1-800-800-7310

Before you call, make sure that you have both your model and serial number ready. By having the model and serial number ready, you help the Customer Support Representative give you faster service. To find your units model and serial number, see SECTION 3: FINDING YOUR MODEL NUMBER.

SECTION 5: UNPACKING INSTRUCTIONS

REMOVE UNIT FROM CARTON

- Remove staples, break glue on top flaps, or cut tape at carton end and peel along top flap to open carton.
- Remove loose parts included with unit (i.e., owner's manual, etc.).
- Cut along dotted lines and lay carton down flat.
- Remove packing material.
- Roll or slide unit out of carton. Check carton thoroughly for loose parts.

SECTION 6: SET-UP INSTRUCTIONS

This guide covers models 462B 5 H.P. thru 465A 8 H.P. chipper shredders. Much of this guide pertains to both models. However, there are some areas where only one model is covered. Use only the information that is appropriate for your model.

Start with Step 1 to set-up you new chipper shredder.

All models.

1. Pull the spark plug wire off of the spark plug.
See Figure 1
2. Remove six hex nuts (A) and six washers (B) from the weld studs on the flail housing. Leave the support plate in place on the weld studs.
See Figure 2
3. Place hopper assembly into position in front of flail housing. Align holes in hopper assembly collar with weld studs on flail housing.
4. Slide hopper assembly onto weld studs.
5. Replace the washers (B) and the hex nuts (A).
6. Tighten the hex nuts (A).
7. Lift hopper until it clicks into the raised position.
8. Remove wing knobs (C) from each side of the discharge chute opening on the chipper shredder. **See Figure 3**
9. Use two 7/16" wrenches to remove hex lock nut (D). Remove two spacers (E), and hex bolt (F) from top of the housing assembly. For easy assembly, do not remove the second spacer from the hex bolt.
10. Place the discharge chute in position on the discharge opening. Insert hex bolt (F) and spacer (E) through hinge on discharge chute and housing (spacer fits inside of hinge).
11. Place second spacer (E) over hex bolt (F) inside the other half of the hinge. Secure with hex lock nut (D). Tighten securely.
12. Secure both sides of discharge chute to flail housing using wing knobs (C). Tighten wing knobs.

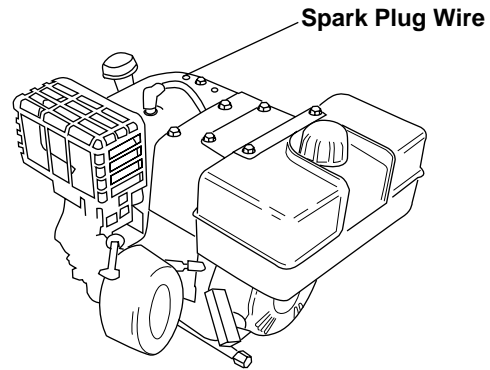

Figure 1

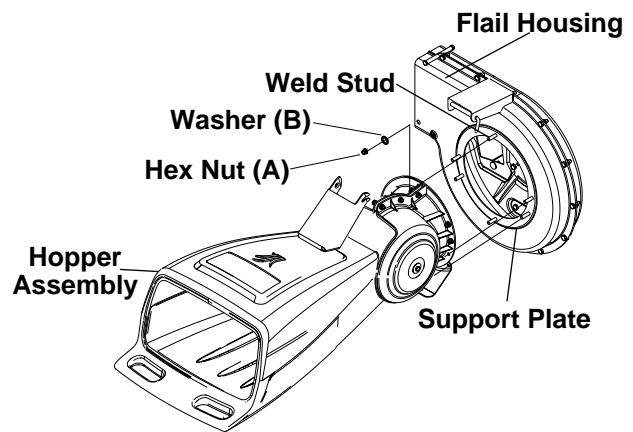

Figure 2

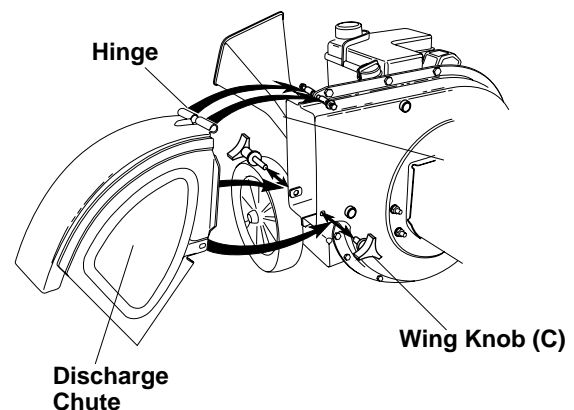
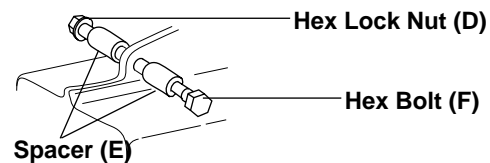

Figure 3

ATTACHING THE CHIPPER CHUTE (Model 465A 8 H.P. chipper shredder only)

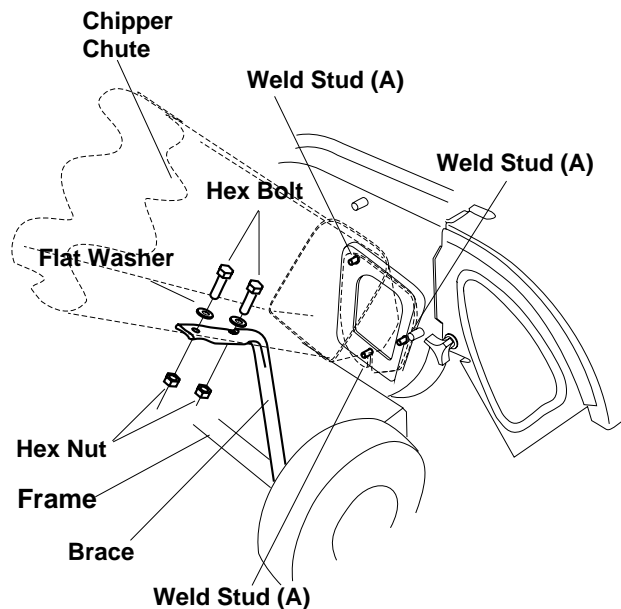

Figure 4

1. Remove the three cupped washers and hex nuts from the weld studs beside (A) the opening on the left side of the housing. **See Figure 4**
2. Remove the two hex bolts, lock nuts, and flat washers from the two holes on the upper end of the brace.
3. Place the chipper chute over the weld studs so the slot on the chute is towards the bottom. Align the three holes on the chute with the three weld studs.
4. Replace the three cupped washers (cupped side against the chipper chute) and hex nuts that you removed in step 1. Do not tighten the nuts at this time. Make sure to place the cupped side of the washer against the chipper chute.
5. Your unit is shipped with one end of the brace already secured to the lower frame. Loosen the bolts securing the brace to the frame.
6. Align the holes on the chute with the holes on the brace.
7. Attach brace to chipper chute with the hardware removed earlier from the brace. See the illustration above for proper order. Tighten.
8. Tighten the bolts securing the brace to the frame.
9. Tighten the three nuts on the weld studs holding the chipper chute to the flail housing.

ALL MODELS

1. To attach the bag, place the opening of the bag over the chute deflector so it completely covers the chute deflector. **See Figure 5**
2. Depress the plunger on the drawstring, and pull on the drawstring until the bag is tight around the chute opening. Release plunger to lock it into position. **See Figure 5**

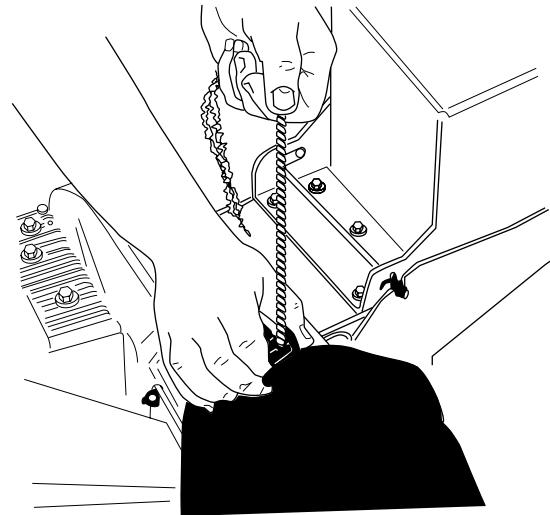

Figure 5

3. Fill engine with oil as instructed in separate engine manual included with your unit.

SECTION 7: CONTROLS

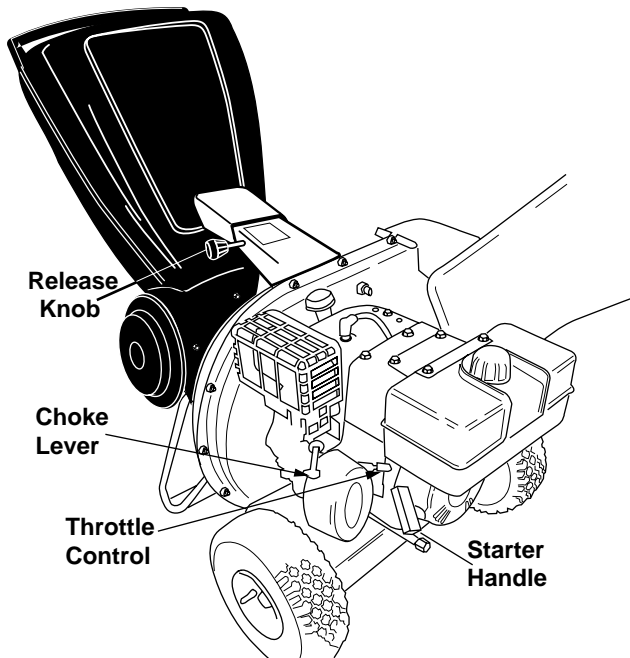

Figure 6

Release Knob: Used to release the hopper when raising or lowering.

Choke Lever: Used to enrich the fuel mixture in the carburetor when starting a cold engine.

Starter Handle: Used to manually start the engine.

Hopper Assembly: Allows leaves and small branches up to 1" diameter to be fed into the impeller for chipping and shredding. Lower the hopper to collect raked material for shredding.

Throttle Control (if equipped): Regulates speed of the engine.

Chipper Chute: Allows bulky vegetation like stalks or heavy branches to be fed into the impeller for chipping and shredding. Maximum diameter is 3" on model 465A and 2" on model 462B.

Catcher Bag (Not Shown): Used to collect the shredded material.

SECTION 8: OPERATION

STOPPING ENGINE

Move throttle control lever to STOP position. Disconnect spark plug wire and move away from spark plug to prevent accidental starting.



WARNING: Before using your chipper-shredder, again refer to the **safety practices** of this manual. **Always be careful.**

GASOLINE AND OIL FILL-UP

See engine manual included with your unit

- If the unit runs out of gas as it is shredding or chipping, it may be necessary to unclog the unit before it can be restarted. Refer to Removing the Flail Screen in Maintenance section.

STARTING ENGINE



WARNING: Be sure **no one other than the operator** is standing near the chipper-shredder while starting or operating. **Do not operate** this chipper-shredder unless the chute deflector has been properly installed and is secured with the hand knobs.

NOTE: To prevent the unit from sliding, place your foot firmly against the wheel.

1. Attach spark plug wire and rubber boot to spark plug.
2. Move starter switch to ON position.
3. Move choke lever to CHOKE position.
4. If restarting a warm engine **after a short shutdown**, move choke lever to No Choke position.
5. Grasp starter handle and pull rope out slowly until engine reaches start of compression cycle (rope will pull slightly harder at this point). Let the rope rewind slowly.
6. Pull rope with a rapid full arm stroke. Let rope return to starter slowly.
7. When engine starts, move choke lever to half choke position until engine runs smoothly and then to No Choke position.
8. If engine **fails to start** after three pulls, move choke lever to No Choke position and pull starter rope again.
9. If engine fires, but **does not continue to run**, move choke lever to Full Choke position and pull rope again.

10. Move choke lever to OFF position as engine warms up.

NOTE : A noise will be heard when finding the start of the compression cycle. This noise is caused by the flails and fingers which are part of the shredding mechanism falling into place, and should be expected. In addition, the flails and fingers will be noisy after the engine is started, until the impeller reaches full speed.

USING YOUR CHIPPER-SHREDDER



WARNING: Do not attempt to shred or chip any material other than vegetation found in a normal yard (i.e., branches, leaves, twigs, etc.).

- Leaves and small branches up to 1/2" diameter (maximum) can be fed into the hopper assembly when it is in the raised or lowered position.
- For model 462B (5 H.P.), bulky material, such as stalks or heavy branches, up to 2" in diameter should be fed into the chipper chute.
- For model 465A (8 H.P.), bulky material, such as stalks or heavy branches, up to 3" in diameter should be fed into the chipper chute.



WARNING: Do not put material larger than is specified into the hopper, and/or into the chipper chute. Personal injury or damage to the machine could result.

- If it becomes necessary to push material into the chipper-shredder, use a small diameter stick -- NOT YOUR HANDS. The stick should be small enough that it will be ground up if it gets into the impeller assembly.

LOWERING THE HOPPER ASSEMBLY

1. To lower the hopper assembly, use one hand to grasp the hand-hold at the top of the hopper assembly and lift slightly.
2. Pull out on the release knob, and lower the hopper assembly to the ground.

NOTE: For best performance, it is important to keep the shredding blade and the chipper blades sharp. If the composition of the material being discharged changes (becomes stringy, etc.) or if the rate at which the material is discharged slows down considerably, it is likely that the shredding blade and/or chipper blades are dull and need to be sharpened or replaced. Refer to Maintenance section.

IMPORTANT: There is a flail screen located inside the housing in the discharge area. If the flail screen becomes clogged, remove and clean as instructed in the Maintenance section.



WARNING: The chipper-shredder discharges materials with considerable velocity. **Keep away** from the area around the discharge chute. Always **stop the engine** and disconnect spark plug wire when removing or attaching the bag, changing containers, or removing the shredded material. Wear safety glasses and gloves whenever using your chipper-shredder.

SECTION 9: MAINTENANCE

GENERAL RECOMMENDATIONS

- Always observe safety rules when performing any maintenance.
- The warranty on this chipper shredder does not cover items that have been subjected to operator abuse or negligence. To receive full value from the warranty, operator must maintain the chipper shredder as instructed in this manual.
- Periodically check all fasteners and make sure these are tight.



WARNING: Always stop the engine and **disconnect** the spark plug wire before performing any maintenance or adjustments. **Never remove discharge chute** till the engine has completely stopped.



WARNING: Temperature of muffler and nearby areas **may exceed 150° F(65°C)**. Avoid these areas.

LUBRICATION

Lubricate the pivot points on the release knob bracket, hopper assembly, chute deflector and once a season using a light oil.

CLEANING

- Clean engine periodically. Remove dirt and debris with a cloth or brush.
- Frequently remove leaves, dirt and debris from cooling fins, air intake screen and levers and linkage. This will help ensure adequate cooling and correct engine speed.

- Clean the chipper shredder by running water from a hose through the hopper assembly and chipper chute with the engine running. Allow the chipper-shredder to dry thoroughly.

NOTE: Cleaning with a forceful spray of water is not recommended as water could contaminate the fuel system.

- Wash the bag periodically with water. Allow to dry thoroughly in the shade. Do not use heat.

ENGINE OIL

The engine oil is the most important “insurance policy” your new chipper shredder has. It protects it from excess wear and tear and helps the cooling process. It is important that you maintain the engine oil at the proper level and that it is changed on a regular basis.

- Service the engine oil according to the separate engine owner’s guide supplied with your chipper shredder.

AIR CLEANER

The air cleaner prevents damaging dirt, dust, etc., from entering the carburetor and being forced into the engine and is important to engine life and performance. **Never run** the engine without air cleaner completely assembled.

- Service the air cleaner according to the separate engine owner’s guide supplied with your chipper shredder.

CARBURETOR



WARNING: If any adjustments are made to the engine while the engine is running (e.g. carburetor), **keep clear of all moving parts.** Be careful of **heated surfaces** and muffler.

- Service the carburetor according to the separate engine owner’s guide supplied with your chipper shredder.

ENGINE SPEED

- The engine speed on your chipper-shredder has been set at the factory. Do not attempt to increase engine speed or it may result in personal injury. If you believe the engine is running too fast or too slow, take your chipper-shredder to the nearest service center for repair and adjustment.

SPARK PLUG

- Service the spark plug according to the separate engine owner’s guide supplied with your chipper shredder.

REMOVING THE FLAIL SCREEN (See Figure 7)

If the discharge area becomes clogged, remove the flail screen and clean area as follows:

1. Stop engine, make certain the chipper-shredder has come to a complete stop and disconnect spark plug wire from the spark plug before unclogging the chute.
2. Remove the two hand knobs on each side of the discharge chute (also called the chute deflector).
3. Lift the discharge chute up, and keep it out of the way.
4. Remove two hairpin clips from the clevis pins which extend through the housing. Remove the clevis pins.
5. Pull the flail screen from inside the housing.
6. Clean the screen by scraping or washing with water.
7. Reinstall the screen.
8. Put the discharge chute back to its original position and tighten the hand knobs.

NOTE: Be certain to reassemble the flail screen with the curved side down

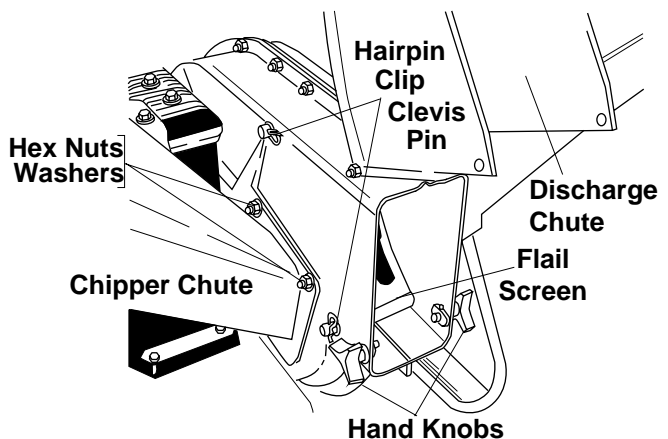

Figure 7

SHARPENING OR REPLACING THE CHIPPER BLADES (See Figure 8)

All models

1. Disconnect spark plug wire and move it away from spark plug.
2. Remove the flail screen as instructed in previous section.

- Using a 1/2" wrench, remove the chipper chute by removing three hex nuts and washers.

Model 465A only

- Use a 7/16" wrench, to remove the brace holding the chipper chute to the frame by removing the hex bolts.

All models

- Rotate the impeller assembly by hand until you locate one of the two chipper blades in the chipper chute opening. Remove the blade, using a 3/16" allen wrench on the outside of the blade and 1/2" wrench on the impeller assembly (inside the housing).

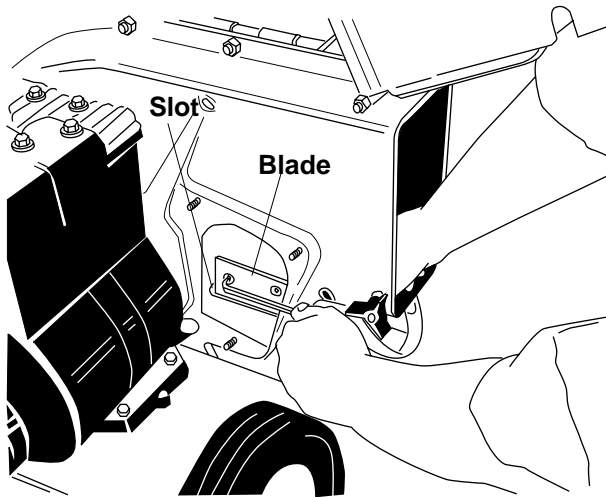

Figure 8

- Remove the other blade in the same manner.
- Replace or sharpen blades.
- If sharpening, make certain to remove an equal amount from each blade.
- Reassemble in reverse order. Make certain blades are reassembled with the sharp edge facing the direction shown in Figure 8 (sharp edge is assembled toward the slotted opening at the bottom).
- Torque bolts and nuts to 250-350 inch-pounds.

SHARPENING OR REPLACING THE SHREDDER BLADE

The shredder blade may be removed for sharpening or replacement as follows. **See Figure 9**

- Disconnect spark plug wire and move it away from spark plug.
- Lower the hopper assembly. Block up the housing.

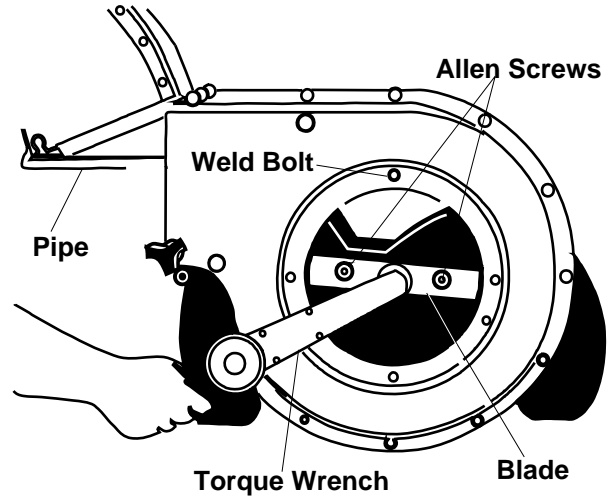

Figure 9

- Remove the six hex lock nuts and lock washers from the housing weld bolts using a 1/2" wrench. Separate the chipper-shredder into two halves.
- Remove the support plate.

NOTE: When reassembling, make certain the embossed tab faces inward towards the impeller, and opening on the support plate is toward the bottom of the unit.

- Remove the two hand knobs and cupped washers which secure the discharge chute. Raise the discharge chute.
- Insert a 1/2" or 3/4" diameter pipe through the flail screen into the impeller to keep it from turning, or remove the flail screen and insert a piece of wood (2 x 4) into the chute opening.
- Remove the two outside screws on the blade, using a 3/16" allen wrench and a 1/2" wrench.
- Remove the blade by removing the center bolt, lock washer and flat washer.



WARNING: Use caution when removing the blade to avoid contacting the weld bolts on the housing.

- When sharpening the blade, follow the original angle of grind as a guide. It is extremely important that each cutting edge receives an equal amount of grinding to prevent an unbalanced blade.
- An unbalanced blade will cause excessive vibration when rotating at high speeds and may cause damage to the unit. The blade can be tested for balance by balancing it on a round shaft screwdriver or nail. Remove metal from the heavy side until it is balanced evenly. **See Figure 10**

11. When reassembling the blade, tighten center bolt to between 550 and 650 inch-pounds and the two outer bolts to between 250 and 350 inch-pounds, or lacking torque wrench, tighten securely.

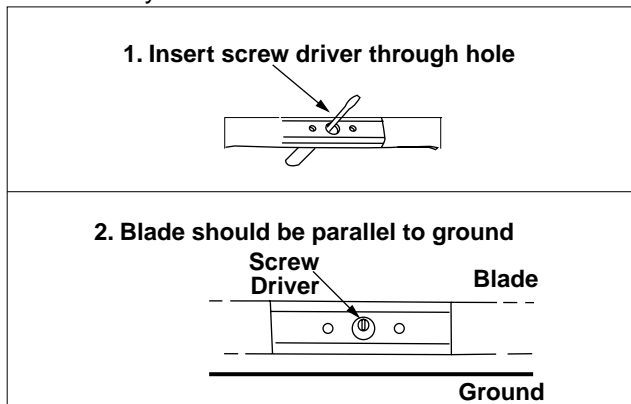

Figure 10

SECTION 10: OFF-SEASON STORAGE

Prepare your chipper-shredder for storage at the end of the season or if the unit will not be used for 30 days or more. The following steps should be taken to prepare your shredder for storage.

1. Clean and lubricate the shredder thoroughly.
2. Refer to engine manual for correct engine storage instructions.
3. If storing in an unventilated or metal storage shed, coat metal parts with a light oil or silicone to prevent rust.
4. Store in a cool dry place. Do not store next to corrosive materials such as fertilizer.

SECTION 11: TROUBLE SHOOTING GUIDE

Trouble	Possible Cause(s)	Corrective Action
Engine fails to start	Dirty air cleaner. Choke not in ON position. Spark plug wire disconnected. Cannot pull recoil cord. Fuel tank empty, or stale fuel. Fuel shut-off valve closed (if so equipped). Faulty spark plug.	Refer to the engine manual packed with your unit. Move switch to ON position. Connect wire to spark plug. Obstruction lodged in impeller. Stop immediately and disconnect spark plug wire. Remove lodged object. Fill tank with clean, fresh gasoline. Fuel will not last over thirty days unless a fuel stabilizer is used. Open fuel shut-off valve. Clean, adjust gap or replace.
Loss of power; operation erratic	Spark plug wire loose. Unit running on CHOKE. Blocked fuel line or stale fuel. Water or dirt in fuel system. Carburetor out of adjustment. Dirty air cleaner.	Connect and tighten spark plug wire. Move choke lever to OFF position. Clean fuel line; fill tank with clean, fresh gasoline. Fuel will not last over thirty days unless a fuel stabilizer is used. Disconnect fuel line at carburetor to drain fuel tank. Refill with fresh fuel. Refer to the engine manual packed with your unit. Refer to the engine manual packed with your unit.
Engine overheats	Carburetor not adjusted properly. Dirty air cleaner. Engine oil level low.	Refer to the engine manual packed with your unit. Refer to the engine manual packed with your unit. Fill crankcase with proper oil.
Too much vibration	Loose parts or damaged impeller.	Stop engine immediately and disconnect spark plug wire. Have unit serviced by an authorized service dealer.
Unit does not discharge	Discharge chute clogged. Low engine RPM. Foreign object lodged in impeller.	Stop engine immediately and disconnect spark plug wire. Clean flail screen and inside of housing. See Maintenance section of this manual. Always run engine at full throttle Stop engine immediately and disconnect spark plug wire. Remove lodged object.
Rate of discharge slows considerably or composition of discharged material changes	Low engine RPM. Shredding blade and/or chipper blades dull.	Always run engine at full throttle Replace shredding and chipper blades or see your authorized service dealer.

Note: For repairs beyond the minor adjustments above, contact your local authorized service dealer.

SECTION 12: ILLUSTRATED PARTS LIST

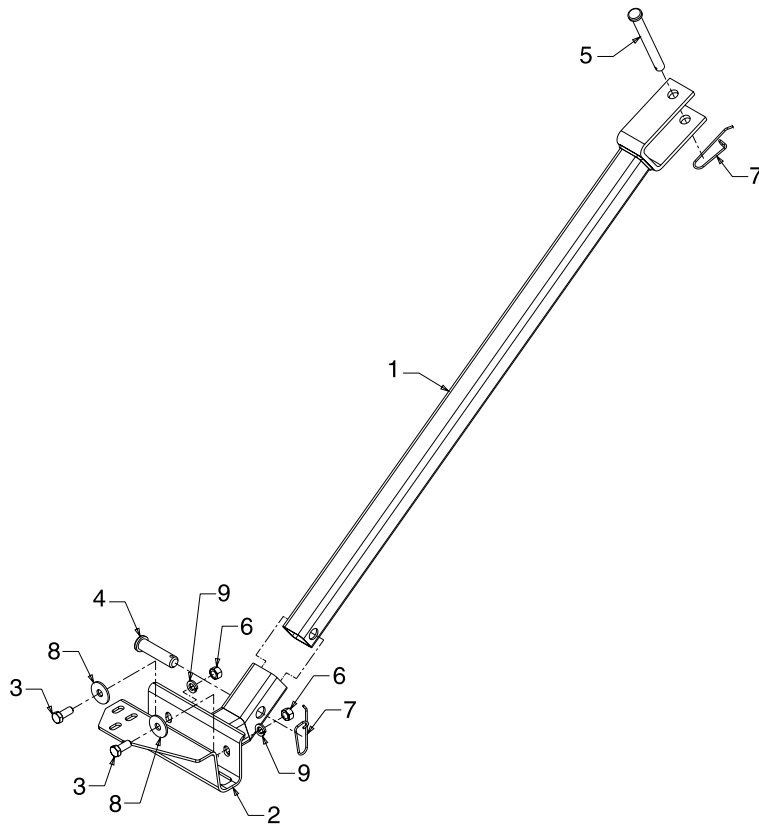

TOW HITCH KIT Model Number 290-010-000 For Models 462B, 463C, 465A

REF. NO.	PART NO		DESCRIPTION
1	681-0133	N	Tow Bar Tongue
2	681-0134	N	Tow Bar Base
3	710-3001		Hex Hd. Cap Scr. 3/8-16:.880 Lg.
4	711-0299		Pin, Clevis - .625 x 2.40 Lg.
5	711-0835		Pin, Clevis - .500 Dia. x 4.62 Lg.
6	712-0798		Hex Nut 3/8-16
7	732-0194		Spring Pin
8	736-0133		Fl. Wash. .411 x 1.25 x 1.00
9	736-0169		Lock Wash. 3/8 Reg.

Model 462B, 463C, 465A

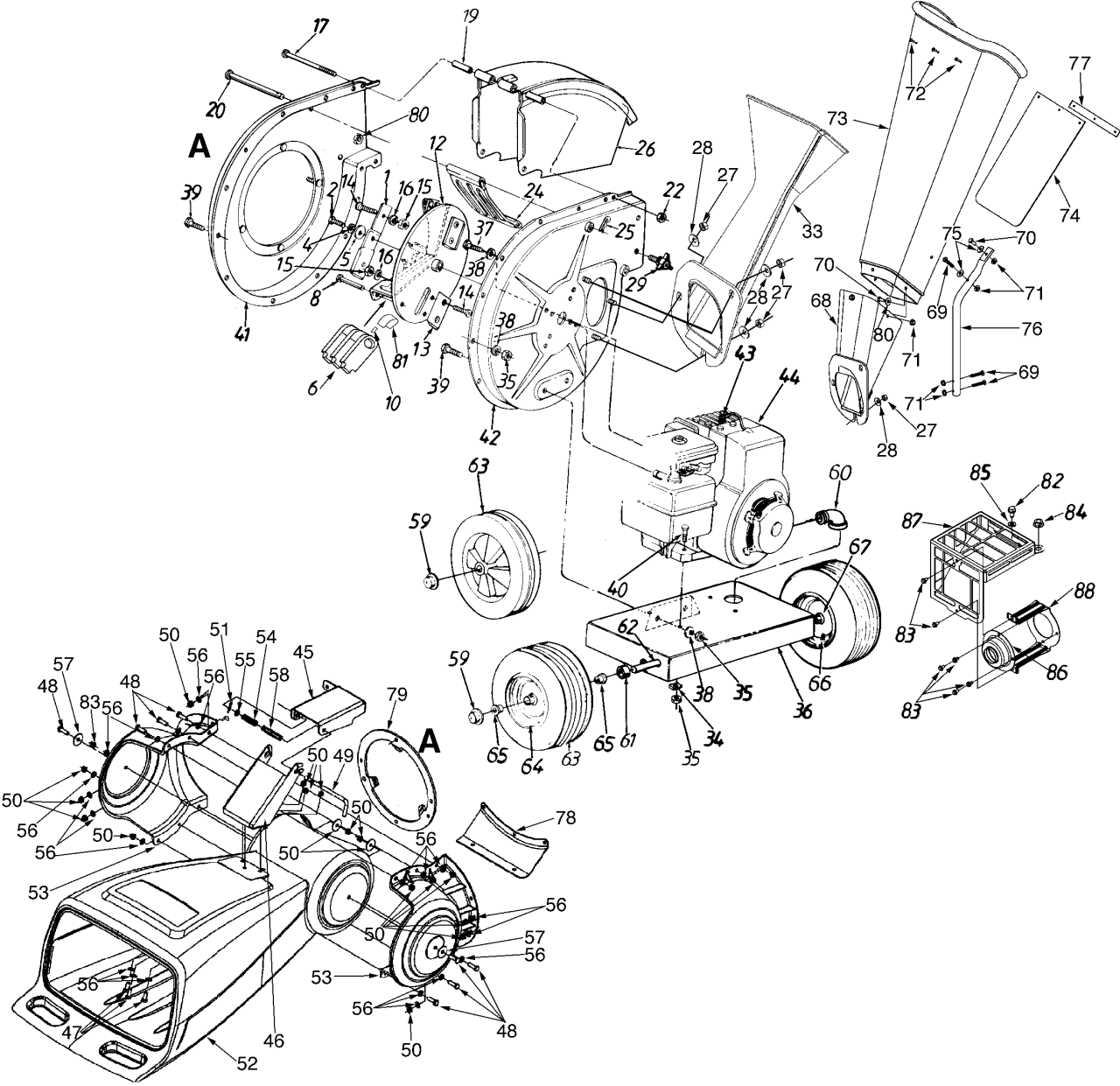

Model 462B, 463C, 465A

REF. NO.	PART NO.	DESCRIPTION	REF. NO.	PART NO.	DESCRIPTION
1	742-0571	Blade	52	731-1707	N Hopper
2	710-1254	Hx Patch Bolt 3/8-24 x 2.25" (Gr. 8)	53	731-1710	N Collar—Hopper
4	736-0217	L-Wash. 3/8" I.D. H.D.	54	732-0306	Compression Spring
5	736-0247	Fl-Wash. .406" I.D. x 1.25" O.D. Hdn.	55	736-0117	Flat Wash. 3/8 x .620 x .033
6	719-0329	Flail Blade	56	736-0264	Flat Wash. .330 x .630 x .06
8	711-0833B	Clevis Pin .496" Dia.	57	736-0362	Flat Wash. .320 I.D. x 1.25 O.D.
10	715-0166	Spring Roll Pin 1.00" Lg.	58	750-0785	Spacer .382 I.D. x .50 O.D. x 1.12
12	681-0030	Impeller Ass'y. Comp. (Incl. Ref. 1, 6, 8, 10, 12, 13, 14)	59	726-0214	Push Cap 5/8" Dia. Rod
13	781-0490	Chipper Blade	60	737-0195	Drain Elbow†
14	710-1054	Flat Hd. Scr. 5/16-24 x .75" Lg.	61	750-0786	Spacer .64 I.D. x .38" Lg.
15	712-0411	Hex Top L-Nut 5/16-24 (Gr. 5)	62	738-0814	Shredder Axle††
16	736-0119	L-Wash. 5/16" I.D.		738-0813	Shredder Axle†††
17	710-0825	Hex Bolt 1/4-20 x 3.75" Lg.	63	734-1600	Wheel Ass'y. Comp.††
19	750-0793	Chute Hinge Spacer 1.66" Lg.		734-1597	Wheel Ass'y. Comp.†††
20	711-0835	Clevis Pin .5" Dia. x 4.62" Lg.	64	734-1455A	Rim Only†††
22	712-3027	Hex Flg. L-Nut 1/4-20 Thd.	65	741-0487A	Flange Bearing .632" I.D.†††
24	781-0457	Shredder Screen	66	734-0255	Air Valve†††
25	714-0149B	Internal Cotter Pin 3/8" Dia.	67	737-0211	Grease Fitting xx
26	681-0094	N Chute Deflector Ass'y.	68	681-0068	Chute Ass'y. xx
27	712-3010	Hex Nut 5/16-18 Thd. (Gr. 5)	69	710-0106	Hex Bolt 1/4-20 x 1.25 xx
29	681-0048	Hand Knob Ass'y.	70	710-0258	Hex Bolt 1/4-20 x 0625 xx
33	681-0095	Chipper Chute Ass'y.†	71	712-3027	Lock Nut 1/4-20 xx
34	736-0170	Spec. L-Wash. 5/16" I.D.	72	728-0175	Pop Rivet xx
35	712-3004A	Hex Nut 5/16-18 Thd. (Gr. 5)	73	731-1899	N Chipper Chute xx
36	781-0510B	N Shredder Frame	74	735-0249	Chute Flap xx
37	710-0157	Hex Bolt 5/16-24 x .75" Lg.	75	736-0173	Flat Wash. .28 I.D. xx
38	736-0119	L-Wash. 5/16" I.D.	76	749-1004	N Chute Support xx
39	710-3008	Hex Bolt 5/16-18 x .75" Lg. (Gr. 5)	77	781-0633	Flat Strip xx
40	710-0442	Hex Bolt 5/16-18 x 1.50" Lg.	78	781-0515	Front Support Bracket
41	681-0004A	N Flail Housing Ass'y.—L.H.	79	781-0574	Back Up Plate
42	681-0117	N Flail Housing Ass'y.—R.H.	—	764-0199A	Bag (Not Shown)
43	735-0639	Spark Plug Boot (Optional)		723-0400	Safety Glasses (Not Shown)
44	—	Engine	80	726-0211	U-Nut
45	681-0104	N Bracket Ass'y. - R.R.	81	781-0735	Spring Clip
46	681-0123	N Bracket Ass'y. - Frt.	82	710-0599	Scr. TT. 1/4-20: .5"
47	710-0118	Hex Bolt 5/16-18 x .75" Lg. (Gr. 2)	83	710-1502	Scr. AB 8-18: .375
48	710-0376	Hex Bolt 5/16-18 x 1.0" Lg. (Gr. 5)	84	712-3004A	Nut-Lock Hx. Flg. 5/16-18
49	711-1128	N Lock Rod	85	7360329	Lockwasher
50	712-0429	Hex L-Nut 5/16-18	86	751-0447	Deflector
51	714-0104	Internal Cotter Pin .072 x 1.12 Lg.	87	751-0632	Guard - Muffler
			88	751-0646	Bracket - Muffler Guard

† Model 462B only
 †† Modle 462B/463C
 ††† Model 465A
 xx Model 463C/465A

MANUFACTURER'S LIMITED WARRANTY FOR:



For TWO YEARS from the date of retail purchase within the United States of America, its possessions and territories, MTD PRODUCTS INC will, at its option, repair or replace, for the original purchaser, free of charge, any part or parts found to be defective in material or workmanship. This warranty covers units which have been operated and maintained in accordance with the operating instructions furnished with the unit, and which have not been subject to misuse, abuse, commercial use, neglect, accident, improper maintenance or alteration.

Normal wear parts or components thereof are subject to separate terms as noted below in the "No Fault Ninety Day Consumer Warranty" clause.

All normal wear part failures will be covered on this product for a period of 90 days regardless of cause. After 90 days, but within the two year period, normal wear parts failures will be covered ONLY IF caused by defects in material or workmanship of OTHER component parts. Normal wear parts are defined as batteries*, belts, blades, blade adapters, grass bags, rider deck wheels, seats, snow thrower skid shoes, shave plates and tires.

How to obtain service: Warranty service is available, with proof of purchase, through your local authorized service dealer. To locate the dealer in your area, please check the yellow pages or contact the Customer Service Department of MTD PRODUCTS INC, P. O. Box 368022, Cleveland, Ohio 44136-9722. Phone 1 (800) 800-7310. The return of a complete unit will not be accepted by the factory unless prior written permission has been extended by the Customer Service Department of MTD PRODUCTS INC.

Transportation charges: Transportation charges for the movement of any power equipment unit or attachment are the responsibility of the purchaser.

Units exported out of the United States: MTD PRODUCTS INC does not extend any warranty for

products sold or exported outside of the United States of America, its possessions and territories, except those sold through MTD PRODUCTS INC's authorized channels of export distribution.

Other Warranties:

1. The engine or component parts thereof carry separate warranties from their manufacturers. Please refer to the applicable manufacturer's warranty on these items.
2. *Batteries are covered by a 90-day replacement warranty.
3. Log splitter pumps, valves and cylinders or component parts thereof are covered by a one year warranty.
4. All other warranties, express or implied, including any implied warranty of merchantability or fitness for a particular purpose, are hereby expressly disclaimed in their entirety.
5. The provisions as set forth in this warranty provide the sole and exclusive remedy of MTD PRODUCTS INC's obligations arising from the sales of its products. MTD PRODUCTS INC will not be liable for incidental or consequential loss or damage.

How state law relates to this warranty: This limited warranty gives you specific legal rights, and you may also have other rights which vary from state to state. Certain disclaimers are not allowed in some states and therefore they may not apply to you under all circumstances.

NOTE: This warranty does not cover routine maintenance items such as lubricants, filters, blade sharpening and tune-ups, or adjustments such as brake adjustments, clutch adjustments or deck adjustments. Nor does this warranty cover normal deterioration of the exterior finish due to use or exposure.